

# Housekeeping

- Introduce Jin Ding
- Remarks on the surveys
- Questions
- Homework is in the folder – hint: netstat command
- Approximate class calendar
- Lecture Slides on class web site – Powerpoint viewer, Star office

# Class Calendar - approximate

- Ch 1: 8/27 & 8/29
- Ch 2: 9/5 – 9/12
- Ch 3: 9/14 – 9/21
- Ch 4: 9/24 – 10/1
- Extras and Exam: 10/3 – 10/8
- Ch 5: 10/10 – 10/19
- Ch 6, extras and exam: 10/22 – 11/16
- Ch 8: 11/26 – 12/7
- Ch 7, 9 and extras: 12/10 – 12/14

# Introduction

## Outline

Inter-Process Communication

Physical Building Blocks

Conceptual Building Blocks

Performance Metrics

Failures

# Inter-Process Communication

- Turn host-to-host connectivity into process-to-process communication.
- Fill gap between what applications need/expect and what the underlying technology provides.

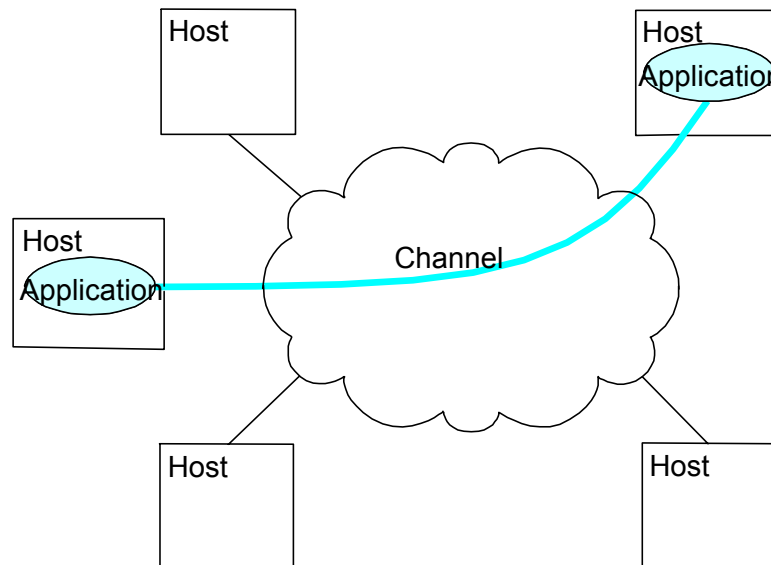

# IPC Abstractions

- Request/Reply
  - distributed file systems
  - digital libraries (web)
- Stream-Based
  - sequential file transfer
  - video: sequence of frames
    - 1/4 NTSC = 352x240 pixels
    - $(352 \times 240 \times 24)/8=247.5\text{KB}$
    - 30 fps = 7500KBps = 60Mbps
  - video applications
    - on-demand video
    - video conferencing

# Building Blocks

- Nodes: PC, special-purpose hardware...
  - hosts
  - switches
- Links: coax cable, optical fiber, radio...

– point-to-point

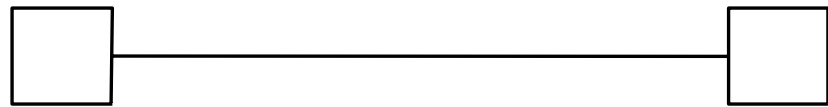

– multiple access

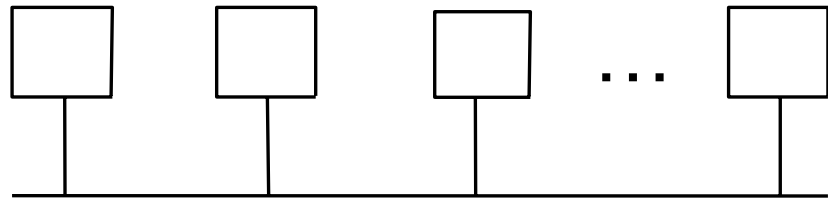

# Addressing and Routing

- Address: byte-string that identifies a node
  - usually unique
- Routing: process of forwarding messages to the destination node based on its address
- Types of addresses
  - unicast: node-specific
  - broadcast: all nodes on the network
  - multicast: some subset of nodes on the network

# Strategies

- Circuit switching: carry bit streams
  - original telephone network
- Packet switching: store-and-forward messages
  - Internet

# Multiplexing

- Time-Division Multiplexing (TDM)
- Frequency-Division Multiplexing (FDM)

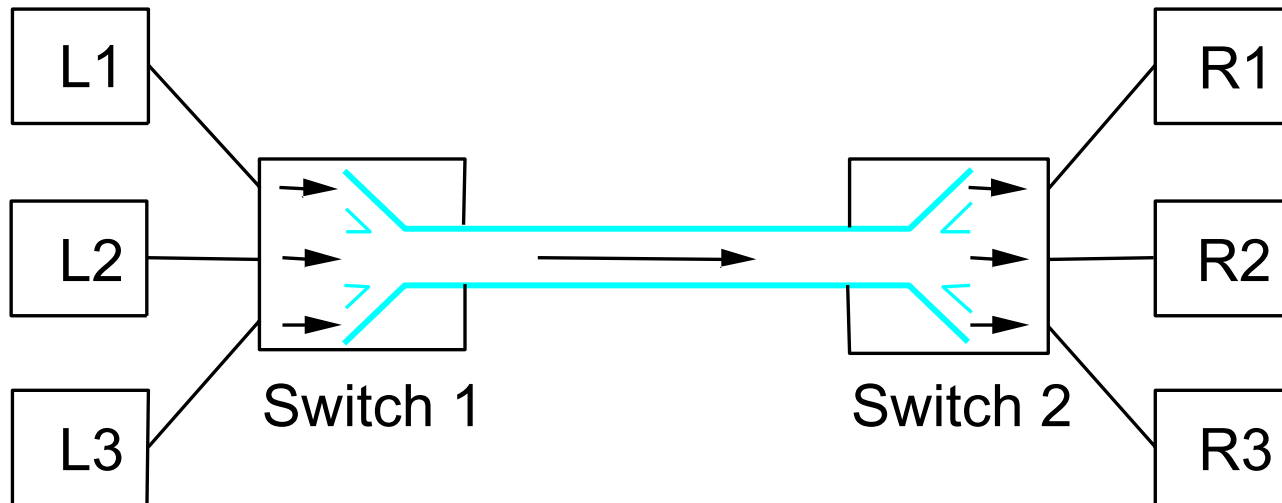

# Statistical Multiplexing

- On-demand time-division
- Schedule link on a per-packet basis
- Packets from different sources interleaved on link
- Buffer packets that are *contending* for the link
- Buffer (queue) overflow is called *congestion*

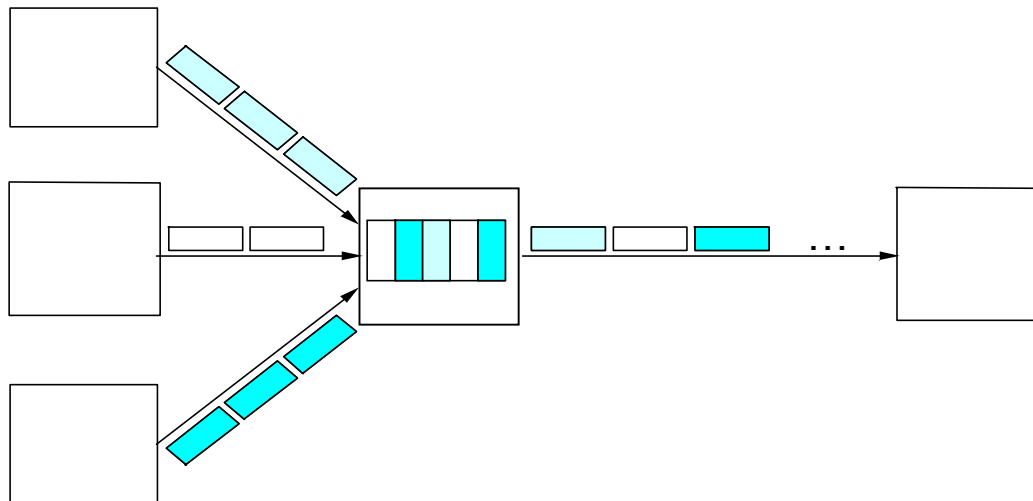

# Layering

- Use abstractions to hide complexity
- Abstraction naturally lead to layering
- Alternative abstractions at each layer

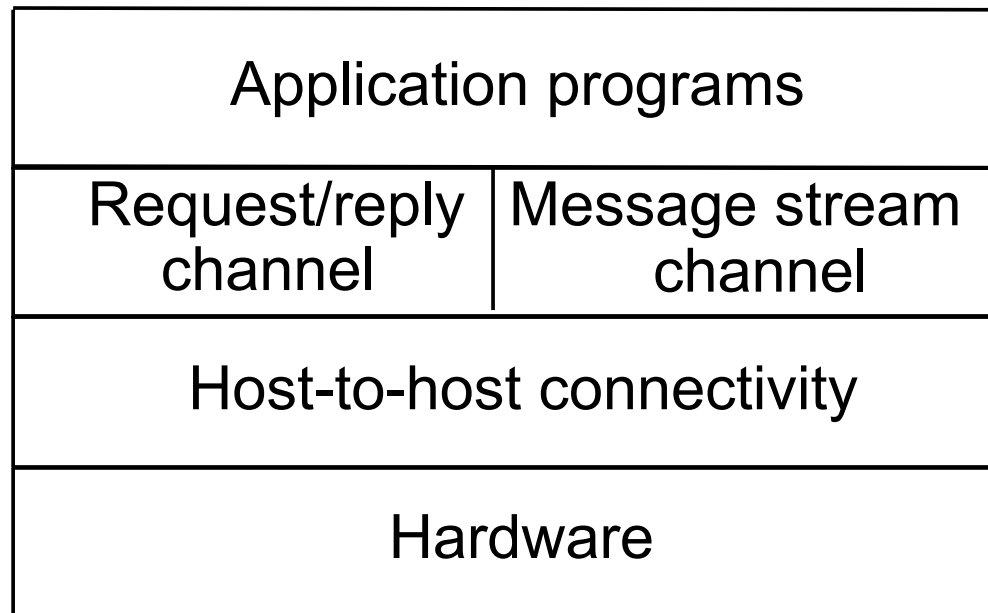

# Protocols

- Building blocks of a network architecture
- Each protocol object has two different interfaces
  - *service interface*: operations on this protocol
  - *peer-to-peer interface*: messages exchanged with peer
- Term “protocol” is overloaded
  - specification of peer-to-peer interface
  - module that implements this interface

# Interfaces

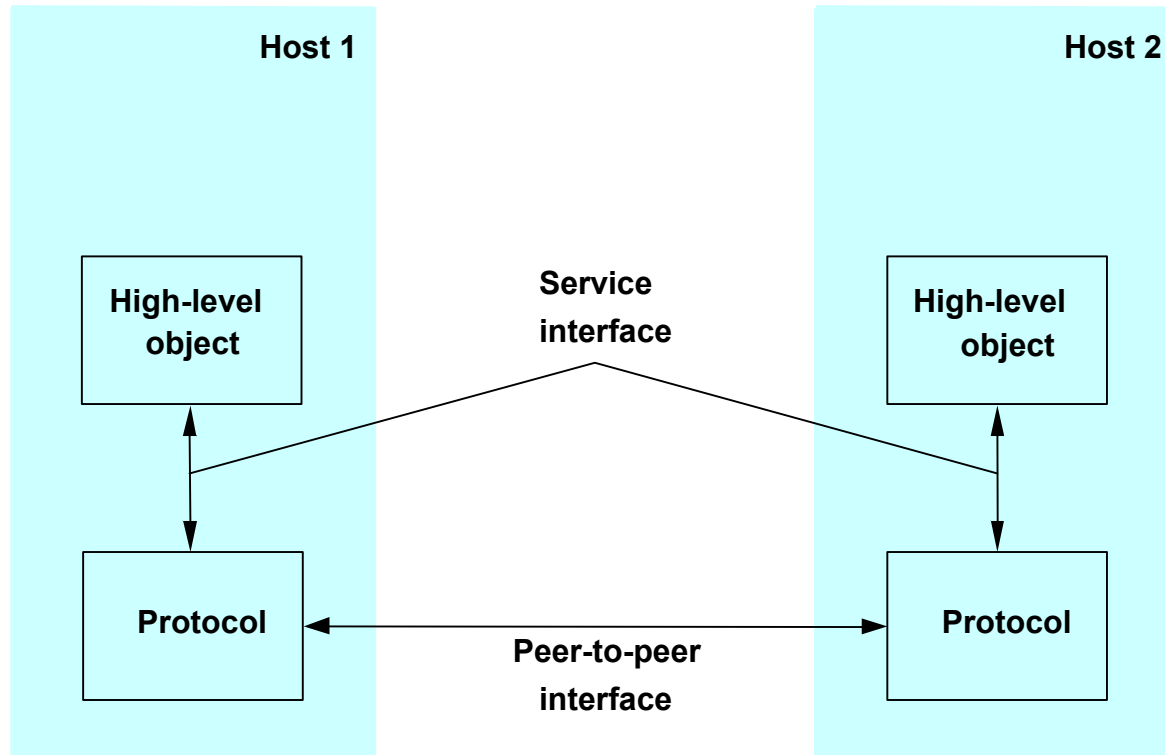

# Protocol Machinery

- Protocol Graph
  - most peer-to-peer communication is indirect
  - peer-to-peer is direct only at hardware level

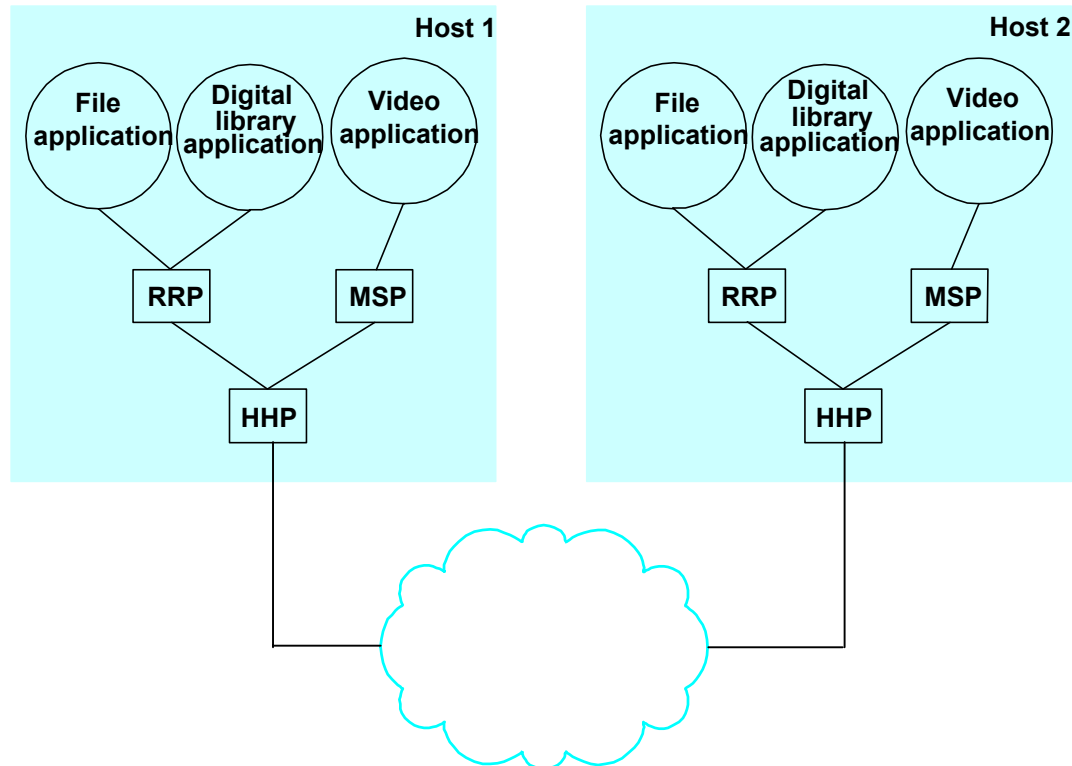

# Machinery (cont)

- Multiplexing and Demultiplexing (demux key)
- Encapsulation (header/body)

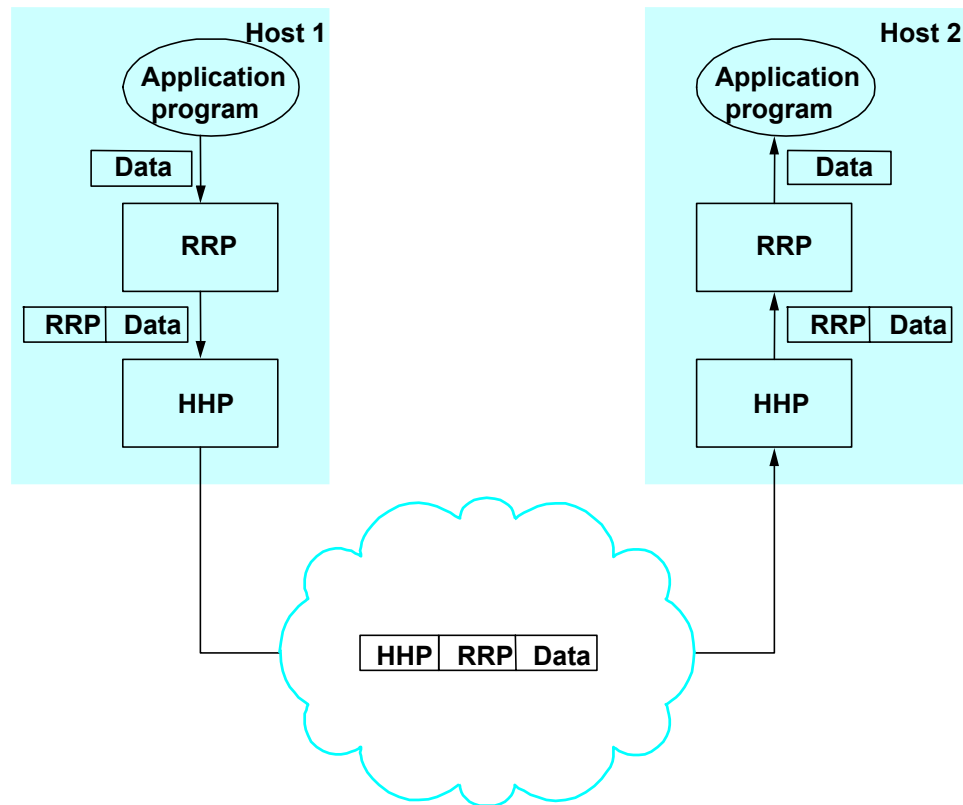

# Internet Architecture

- Defined by Internet Engineering Task Force (IETF)
- Hourglass Design
- Application vs Application Protocol (FTP, HTTP)

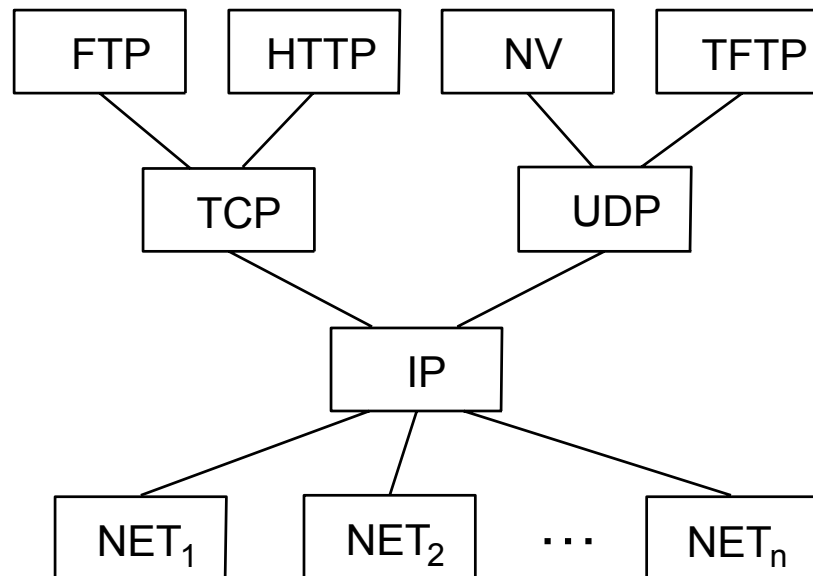

# OSI Architecture

