

	EE351 Midterm Exam. # 1 (Closed notes & book)	School of EECS/ WSU
Sample test		
Name: _____	ID #: _____	

Problem 3:

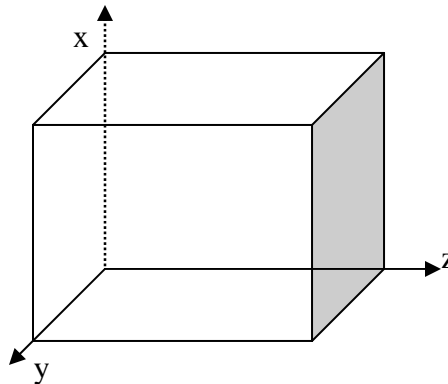

The above waveguide has perfect conducting metal walls and extends to ∞ in the z-direction. It has dimensions $a = 8$ cm and $b = 6$ cm (a along x-axis) and is filled with lossless dielectric ($\mu = \mu_0$ and $\epsilon = 9\epsilon_0$). One of the TE mode has the following component:

$$E_{ys} = \frac{j\omega\mu}{h^2} \left(\frac{\pi}{a}\right) H_0 \sin\left(\frac{\pi x}{a}\right) \cos\left(\frac{3\pi y}{b}\right) e^{-\gamma z}$$

Determine the following:

- a) Mode of operation (m,n)? (2)
- b) u' (the phase velocity in the lossless dielectric)? (3)
- c) The cut off frequency? (4)
- d) The magnetic field vector \vec{H} for the TE₁₀ mode? (6)
- e) The surface current density \vec{K}_s (same as \vec{J}_s in lecture notes) on the $x=0$ wall? (10)

Problem 4:

Given an air filled parallel plate wave guide with plate separation = 1.5 cm. Determine the following and comment whether the mode is supported or not:

a) Cut-off frequencies f_{cm} for TM_0 , TE_0 , TE_1 , TE_2 , and TM_2 modes. (10)

Mode	TM_0	TE_0	TE_1	TE_2	TM_2
f_{cm}					

b) The phase velocities for modes TM_0 , TE_1 , TE_2 , and TM_2 at 15 GHz? (10)

Mode	TM_0	TE_0	TE_1	TE_2	TM_2
u					

c) The lowest order mode that can not propagate at $f=18$ GHz.? (5)